

USB Compliant Li-ion Battery Charger

The ISL9219R5360 is a fully integrated high input voltage single-cell Li-ion battery charger. These chargers are fully in compliance with the USB electrical specification. The chargers perform the CC/CV charge function required by Li-ion batteries. The chargers accept an input voltage up to 28V but are disabled when the input voltage exceeds the OVP threshold, to prevent excessive power dissipation. The 28V rating eliminates the overvoltage protection circuit required in a low input voltage charger.

The fast charge current is programmable with an external resistor, and the end-of-charge (EOC) current is fixed at 50mA for any input source type. When the input power source is identified as a USB port, the host controller will further identify the power type of the port and drive the USBI pin accordingly.

When the battery voltage is lower than the trickle charge threshold, which is also programmable with an external resistor, the charger preconditions the battery with an 85mA constant current. Charge is complete when the charge current reduces to the EOC current level during the CV charge phase. The STAT1 and STAT2 provide unique indication for each charging condition. An internal thermal foldback function protects the charger from any thermal failure.

The STAT1 and STAT2 pins are of open drain type, allowing a simple interface to a microprocessor or an LED. When no adapter is attached or when disabled, the charger draws less than 1µA leakage current from the battery.

Additional features include an OVP protected power-good source, preconditioning of an over-discharged battery, an NTC thermistor interface for charging the battery in a safe temperature range, automatic recharge, and thermally enhanced QFN package.

Ordering Information

PART NUMBER	PART MARKING	TEMP. RANGE (°C)	PACKAGE (Pb-Free)	PKG. DWG. #
ISL9219IRZR5360	219	-40 to +85	20 Ld 3x4 QFN	L20.3x4
ISL9219IRZ-TR5360*	219	-40 to +85	20 Ld 3x4 QFN	L20.3x4

*Please refer to TB347 for details on reel specifications.

NOTE: These Intersil Pb-free plastic packaged products employ special Pb-free material sets, molding compounds/die attach materials, and 100% matte tin plate plus anneal (e3 termination finish, which is RoHS compliant and compatible with both SnPb and Pb-free soldering operations). Intersil Pb-free products are MSL classified at Pb-free peak reflow temperatures that meet or exceed the Pb-free requirements of IPC/JEDEC J STD-020.

Features

- Complete Charger for Single-Cell Li-ion/Polymer Batteries
- Integrated Pass Element and Current Sensor
- No External Blocking Diode Required
- Low Component Count and Cost
- 0.7% Voltage Accuracy
- Programmable Charge Currents
- 250µA (Typ) Suspend Quiescent Current
- USB 100mA/500mA Charge Current Setting
- Charge Current Thermal Foldback for Thermal Protection
- Trickle Charge for Fully Discharged Batteries
- 28V Maximum Voltage for the Power Input
- Charge Status Indication
- Less than 1µA Leakage Current Off the Battery when No Input Power Attached or Charger Disabled
- Ambient Temperature Range: -40°C to +85°C
- Pb-free (RoHS Compliant)

Related Literature

- Technical Brief TB363 “Guidelines for Handling and Processing Moisture Sensitive Surface Mount Devices (SMDs)”
- Technical Brief TB379 “Thermal Characterization of Packaged Semiconductor Devices”
- Technical Brief TB389 “PCB Land Pattern Design and Surface Mount Guidelines for QFN Packages”

Pinout

ISL9219R5360
(20 LD 3X4 QFN)
TOP VIEW

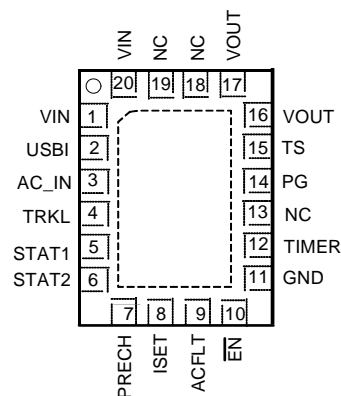

ISL9219R5360

Absolute Maximum Ratings

Supply Voltage (VIN)	-0.3V to 30V
Output Pin Voltage (STAT1, STAT2, PG)	-0.3V to 7V
All Other Pins	-0.3V to 5.5V
Maximum Output Current	1.5A

Recommended Operating Conditions

Ambient Temperature Range	-40°C to +85°C
Maximum Supply Voltage, VIN	.28V
Supply Voltage, VIN	4.3V to 6V
Programmable Charge Current	50mA to 1A

Thermal Information

Thermal Resistance (Junction to Ambient) θ_{JA} (°C/W)	θ_{JC} (°C/W)
3x4 QFN Package (Notes 1, 2)	41 2.5
Maximum Junction Temperature (Plastic Package)	+150°C
Maximum Storage Temperature Range	-65°C to +150°C
Pb-free Reflow Profile	see link below
http://www.intersil.com/pbfree/Pb-FreeReflow.asp	

CAUTION: Do not operate at or near the maximum ratings listed for extended periods of time. Exposure to such conditions may adversely impact product reliability and result in failures not covered by warranty.

NOTES:

- θ_{JA} is measured in free air with the component mounted on a high effective thermal conductivity test board with "direct attach" features. See Tech Brief TB379.
- For θ_{JC} , the "case temp" location is the center of the exposed metal pad on the package underside.
- Parameters with MIN and/or MAX limits are 100% tested at +25°C, unless otherwise specified. Temperature limits established by characterization and are not production tested.

Electrical Specifications

Typical values are tested at VIN = 5V and TA = +25°C, maximum and minimum values are established over the Recommended Operating Conditions, unless otherwise noted.

PARAMETER	SYMBOL	TEST CONDITIONS	MIN (Note 3)	TYP	MAX (Note 3)	UNITS
POWER-ON RESET						
Rising VIN Threshold	V _{POR}		3.4	3.6	3.8	V
Falling VIN Threshold	V _{POR}		2.2	2.4	2.6	V
VIN-BAT OFFSET VOLTAGE						
Rising Edge	V _{OS}		-	90	150	mV
Falling Edge	V _{OS}		10	50	-	mV
AC FAULT DETECTION THRESHOLD						
AC Fault Threshold	V _{ACFLT}		4.3	4.4	4.5	V
STANDBY CURRENT						
VOUT Pin Sink Current	I _{LEAK}	VIN < V _{POR} or \overline{EN} = HI	-	1	5.0	μA
VIN Pin Supply Current	I _{STANDBY}	VOUT floating and \overline{EN} = HI	-	250	300	μA
VIN Pin Supply Current	I _{RUN}	VOUT floating and \overline{EN} = LO	-	1	2	mA
VOLTAGE REGULATION						
Output Voltage	V _{CH}	TA = +25°C, I _{OUT} = 100mA	4.185	4.20	4.215	V
Output Voltage	V _{CH}	I _{OUT} = 100mA	4.169	4.20	4.231	V
Dropout Voltage		V _{OUT} = 4.2V, I _{OUT} = 1A	-	300	430	mV
OVERVOLTAGE PROTECTION						
Overvoltage Protection Rising Threshold	V _{OVPR}		5.64	6.0	6.36	V
Overvoltage Protection Falling Threshold	V _{OVPF}		5.54	5.6	-	V
OUTPUT CURRENT						
Constant Charge Current	I _{CHARGE}	AC input, VIN = 5V, V _{OUT} = 3.8V R _{ISSET} = 24k	0.9	1.0	1.1	A
Output Current Set Voltage	V _{ISSET}	AC input, VIN = 5V, V _{OUT} = 3.8V, I _{OUT} = 1A	2.364	2.4	2.436	V
Constant Charge Current	I _{CHARGE}	USB1 = HI, VIN = 5V, V _{OUT} = 3.8V	380	430	490	mA
Constant Charge Current	I _{CHARGE}	USB1 = LO, VIN = 5V, V _{OUT} = 3.8V	65	85	95	mA
Trickle Charge Current	I _{TRICKLE}	For any input type, VIN = 5V, V _{OUT} = 2V	65	85	95	mA

Electrical Specifications Typical values are tested at $V_{IN} = 5V$ and T_A at $+25^\circ C$, maximum and minimum values are established over the Recommended Operating Conditions, unless otherwise noted. **(Continued)**

PARAMETER	SYMBOL	TEST CONDITIONS	MIN (Note 3)	TYP	MAX (Note 3)	UNITS
End-of-Charge Threshold	I_{MIN}	For any input type, $V_{IN} = 5V$	30	50	70	mA
RECHARGE THRESHOLD						
Recharge Voltage Threshold	V_{RECH}		4.05	4.1	4.15	V
TRICKLE CHARGE THRESHOLD						
Trickle Charge Threshold Voltage	V_{MIN}	PRECH is floating	2.9	3.0	3.1	V
Trickle Charge Threshold Voltage	V_{MIN}	RPRECH = 82.5k	2.375	2.475	2.575	V
Trickle Charge Threshold Hysteresis	V_{MIN_HYS}		35	60	150	mV
TEMPERATURE MONITORING						
Constant Current Source For TS	I_{TS}		4.8	5.0	5.3	μA
Low Battery Temperature Threshold	V_{TMIN}		1.86	1.88	1.91	V
High Battery Temperature Threshold	V_{TMAX}		0.145	0.16	0.175	V
Battery Removal Threshold	V_{RMV}		-	2.25	-	V
Charge Current Foldback Threshold	T_{FOLD}		-	125	-	$^\circ C$
Current Foldback Gain	G_{FOLD}		-	100	-	$mA/^\circ C$
OSCILLATOR						
Oscillation Period	t_{OSC}	$C_{TIME} = 15nF$	2.5	3.0	3.3	ms
DE-GLITCH TIME						
De-Glitch Time For EOC, Recharge	t_{DEG}		40	100	170	ms
LOGIC INPUT AND OUTPUT						
Input High (USBI, \overline{EN} , AC_IN)			1.4	-	-	V
Input Low (USBI, \overline{EN} , AC_IN)			-	-	0.4	V
Open Drain Leakage Current When HI (STAT1, STAT2, ACFLT, TRKL)		Pin Voltage = 6V	-	-	1	μA
Open Drain Sink Current When LOW (STAT1, STAT2, ACFLT, TRKL)		Pin Voltage = 0.3V	20	-	-	mA
VIN to PG Switch						
PMOSFET ON-Resistance	$r_{DS(ON)}$		-	3	5	Ω
Maximum Output Current	I_{PG}		-	60	-	mA

Pin Descriptions

VIN (Pin 1, 20)

Input supply voltage, Connect a $1\mu F$ ceramic capacitor to power ground.

USBI (Pin 2)

USB power type selection logic input. When this pin is left floating or driven to logic LOW, the USB port is regarded as a low-power port with 100mA maximum output current. In such cases, the charge current is internally set to 85mA. When this pin is driven to logic HIGH, the USB port is considered a high-power port with a 500mA maximum current available. In such cases, the charge current is set at 430mA regardless of the ISET resistor. There is a 600k pull-down resistor between the USBI pin to GND.

AC_IN (Pin 3)

Input source type configuration pin. Pull this pin to logic HI to configure the charger for an AC adapter. If this pin is left floating or driven to logic LO, the charger is configured for USB source type, where the charge current is set at 430mA or 85mA, depending on the USBI status. There is a 600k pull-down resistor between the AC_IN pin to GND.

TRKL (Pin 4)

Open-drain indication pin which turns on when charger is in trickle mode, otherwise turns off. This pin is capable to sink 20mA minimum current to drive an LED.

STAT1 (Pin 5)

Open-drain indication pin. In conjunction with STAT2 this pin provides a unique indication for each charging state of the

cycle. This pin is capable to sink 20mA minimum current to drive an LED.

STAT2 (Pin 6)

Open-drain indication pin. In conjunction with STAT1 this pin provides a unique indication for each charging state of the cycle. This pin is capable to sink 20mA minimum current to drive an LED.

PRECHG (Pin 7)

Trickle charge threshold voltage programming input pin. Connect a resistor between this pin and GND to set the threshold voltage by Equation 1:

$$V_{\text{TRKLV}} = \frac{3 \times R_{\text{TRKLV}}}{100} \quad (\text{V}) \quad (\text{EQ. 1})$$

Where R_{TRKLV} is in $k\Omega$, valid for $R_{\text{TRKLV}} \leq 100k\Omega$.

ISET (Pin 8)

Charge-current programming and monitoring pin. Connect a resistor between this pin and the GND pin to set the charge current limit by Equation 2:

$$I_{\text{OUT}} = \frac{24000}{R_{\text{ISET}}} \quad (\text{mA}) \quad (\text{EQ. 2})$$

Where R_{ISET} is in $k\Omega$.

The ISET pin voltage also monitors the actual charge current during the entire charge cycle, including the trickle, constant-current, and constant-voltage phases. However, when the dropout voltage is reached, the ISET pin voltage will no longer follow the output current due to fact that the output current is no longer controlled by the IC. When disabled, $V_{\text{ISET}} = 0V$.

When monitoring the charging current at USB input, to achieve the best accuracy of current monitoring, a one-point calibration is recommended determine a calibration factor K. The procedure is described in Equation 3:

$$I_{\text{OUT-calibrated}} = \frac{I_{\text{OUTM}} \times V_{\text{ISET}}}{V_{\text{ISETM}}} \quad (\text{EQ. 3})$$

Where I_{OUTM} is the applied known current for the calibration and V_{ISETM} is the resulting voltage measured at the V_{ISET} pin with a given R_{ISET} . Applying this procedure at each system during the manufacturing process can result in the best accuracy. However if it is too difficult to implement the procedure during the manufacturing process, using an average value for $I_{\text{OUTM}}/V_{\text{ISETM}}$ through characterizing some parts at a reasonably large sample size can also achieve good accuracy.

ACFLT (pin 9)

Open-drain indication pin which turns off when the adapter plugged in does not have sufficient current rating and the resulting input voltage is dropped to below 4.4V. This pin is capable to sink 20mA minimum current to drive an

LED. The open drain indication also turns off when an input OVP condition ($V_{\text{IN}} > 6V$) is encountered.

EN (Pin 10)

IC enable input. Drive this pin to logic LO or leave it floating to enable the charger. Drive this pin to logic HI to disable the charger. There is a 600k pull-down resistor between the $\overline{\text{EN}}$ pin to GND.

PG (Pin 14)

The PG pin is a bypass switch that connects to V_{IN} through an internal P-Channel MOSFET when V_{IN} is within the power-good window. Otherwise the PG pin is in a high impedance (floating) state. When V_{IN} is within the power-good window, the PG pin can source up to 60mA output current for the down stream circuit. It is recommended that a 2.2 μF ceramic capacitor be connected at the PG pin to absorb any transient voltage due to the delay turning off the PMOS under a fast OVP condition.

TS (Pin 15)

Input for an external NTC thermistor for temperature monitoring. A 5 μA internal current source is provided at this pin and the pin voltage is monitored and compared with the set thresholds to provide over temperature protection.

TIMER (Pin 12)

The TIMER pin sets the oscillation period by connecting a timing capacitor between this pin and GND. The oscillator also provides a time reference for the charger. The timer function can be disabled by connecting the TIMER pin to GND. If the timer is disabled, there will be no timeout function for any operation mode including trickle charge and fast charge modes.

VOUT (Pin 16, 17)

Charger output pin. Connect this pin to the battery. A 1 μF or larger X5R ceramic capacitor is recommended for decoupling and stability purposes.

GND (Pins 11)

System ground connection

NC (Pins 13, 18, 19)

No connect pins.

EPAD

Exposed pad. Connect to GND electrically. Thermally, connect as much as possible copper to this pad either on the component layer or other layers through thermal vias to enhance the thermal performance.

Typical Application

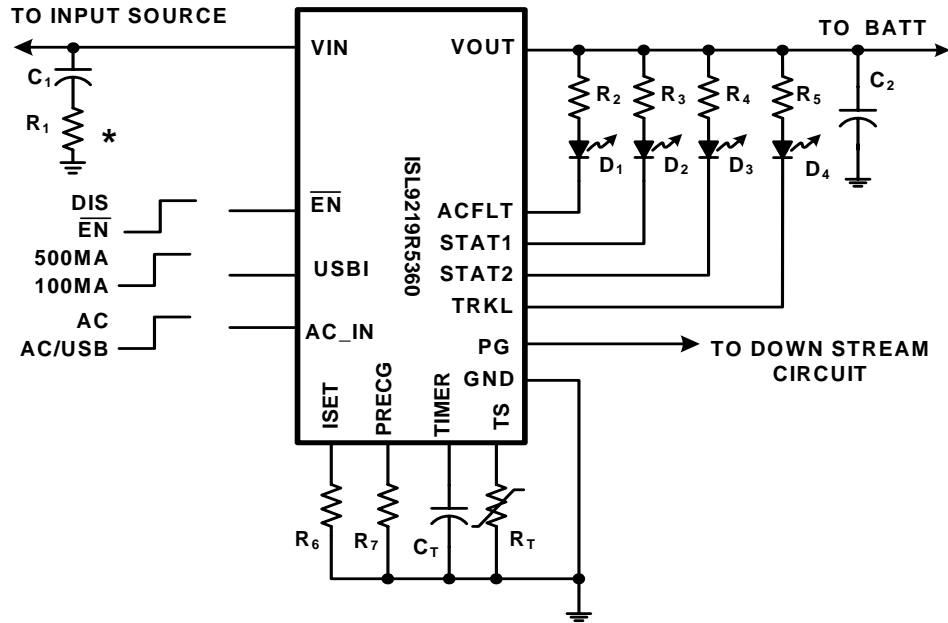

* SEE INPUT AND OUTPUT CAPACITOR SELECTION

Block Diagram

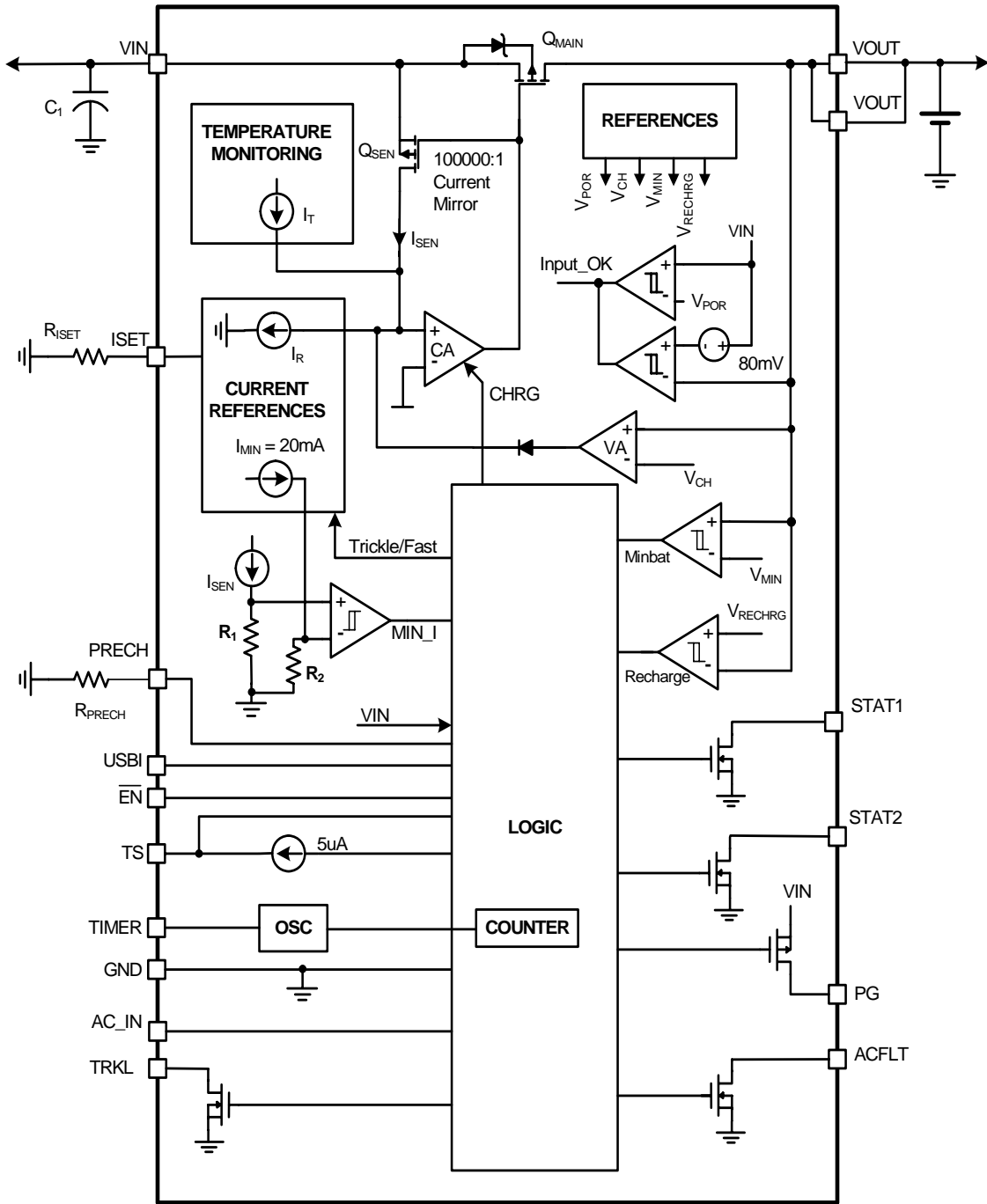

Theory of Operation

The ISL9219R5360 is an integrated charger for single-cell Li-ion or Li-polymer batteries. The ISL9219R5360 functions as traditional linear chargers when powered with a voltage-source adapter. When powered with a current-limited adapter, the charger minimizes the thermal dissipation commonly seen in traditional linear chargers.

As linear chargers, the ISL9219R5360 charges a battery in the popular constant current (CC) and constant voltage (CV) profile. The constant charge current I_{SET} is programmable up to 1A with an external resistor. The charge voltage V_{CH} has 0.7% accuracy over the entire recommended operating condition range. The charger always preconditions the battery with a 85mA constant current at the beginning of a charge cycle, until the battery voltage is verified to be above the minimum fast charge voltage, V_{MIN} . This low-current preconditioning charge mode is named trickle mode. A thermal-foldback feature removes the thermal concern typically seen in linear chargers. The charger reduces the charge current automatically as the IC internal temperature rises above +125°C to prevent further temperature rise. The thermal foldback feature guarantees safe operation when the printed circuit board (PCB) is space limited for adequate thermal dissipation.

USB Compliant Current Setting

The ISL9219R5360 is fully in compliance with the USB electrical specification when a USB port is used as the input source. The input source type can be identified by the host controller. When the USB connector is plugged in, the host controller will identify the device during the enumeration process. The host controller will further identify whether the USB port is a high power port (500mA max current) or low power port (100mA max current). The host controller will then drive the AC_IN and USBI pins thru its GPIO pins, according to the identification results.

If USB compliance is not required, the AC_IN pin can be hard wired to VOUT so that the fast charge current is always set by ISET pin.

Depending on the input source type, the charge current during the constant current phase is:

ISET: determined by RISET if input is an AC adapter

ISET = 430mA if input is a high power USB port

ISET = 85mA if input is a low power port

Power-Good Range

The power-good range is defined by the following three conditions:

1. $V_{IN} > V_{POR}$
2. $V_{IN} - V_{BAT} > V_{OS}$
3. $V_{IN} < V_{OVP}$

where the VOS is the offset voltage for the input and output voltage comparator and the VOVP is the overvoltage protection threshold given in the "Electrical Specification" table on page 2. All V_{POR} , V_{OS} , and V_{OVP} have hysteresis, as given in the Electrical Specification table. If the input voltage is not in the power-good range, the charger will not charge the battery. If the input voltage is within the power good range, the PG pin will be connected to VIN through an internal P-Channel MOSFET with up to 60mA current capability. If the input voltage is not within the power-good range, the PG will be switched off from VIN and turned into a high impedance (floating) state. When an overvoltage condition occurs, the ISL9219R5360 enters the suspend state.

Timeout Function

The charger offers a safety timer for setting the maximum charge time (TIMEOUT) limit to prevent charging a dead battery for an extensively long time. The trickle mode is limited to 1/8 of TIMEOUT limit. The charger automatically re-charges the battery when the battery voltage drops below a recharge threshold.

State Indication

Five indication pins, STAT1, STAT2 and PG are available from the charger to indicate the charge status and fault conditions. The STAT1 and STAT2 are configured to indicate various charging condition as given by the true table in Table 1:

TABLE 1. STAT1 AND STAT2 TRUE TABLE

STAT1	STAT2	CHARGING CONDITION
L	L	Charging
L	H	Charge Complete and during Re-Charge
H	L	Fault
H	H	Suspend

A fault status is triggered under one of these conditions:

1. The TS pin voltage is outside the preset temperature window
2. Timeout occurs before the EOC current has been reached

The PG pin indicates that VIN is within the power-good range.

Applications Information

Power on Reset (POR)

The ISL9219R5360 resets itself as the input voltage rises above the POR rising threshold. The internal oscillator starts to oscillate, the internal timer is reset, and the charger begins to charge the battery. The STAT1/2 pins will indicate the operating condition according to Table 1.

The ISL9219R5360 has a typical rising POR threshold of 3.6V and a falling POR threshold of 2.4V.

Trickle Charge

If the battery voltage is below the trickle charge threshold, the ISL9219R5360 charger delivers a small current to trickle charge the battery until the voltage reaches the fast charge threshold value. The trickle charge threshold is programmed by the resistor connected between the PRECH pin and GND. If the PRECH pin is left floating, a default value of 3.0V is used as the trickle charge voltage.

Charge Cycle

A charge cycle consists of three charge modes: trickle mode, constant current (CC) mode, and constant voltage (CV) mode. The charge cycle always starts with the trickle mode until the battery voltage stays above V_{MIN} (3.0V typical). If the battery voltage stays below V_{MIN} , the charger stays in the trickle mode. The charger moves to the CC mode after the battery voltage is above V_{MIN} . As the battery-pack terminal voltage rises to the final charge voltage (V_{CH}), the CV mode begins. Since the battery terminal voltage is regulated at the constant V_{CH} in the CV mode, the charge current is expected to decline as the cell voltage rises. After the charge current drops below I_{MIN} , which is fixed at 50mA for any input type, the ISL9219R5360 indicates the end-of-charge (EOC) with STAT1 and STAT2. The charging actually does not terminate until the internal timer completes its length of TIMEOUT in order to bring the battery to its full capacity.

The following events initiate a new charge cycle:

- POR
- A new battery being inserted (detected by TS pin)
- Recovery from an battery over-temperature fault
- The \overline{EN} pin is toggled from HI to LO or from HI to floating

Recharge

After a charge cycle completes at a timeout event, charging is prohibited until the recharge condition ($V_{OUT} < V_{RECH}$) is met. Then the charging restarts with the timer reset to zero. The STAT1 and STAT2 indication however, is unchanged.

Internal Oscillator

The internal oscillator establishes a timing reference. The oscillation period is programmable with an external timing capacitor, C_{TIME} , as shown in "Typical Application" on page 5. The oscillator charges the timing capacitor to 1.5V and then discharges it to 0.5V in one period, both with 10 μ A current. The period t_{OSC} is shown in Equation 4:

$$t_{OSC} = 0.2 \cdot 10^6 \cdot C_{TIME} \quad (\text{seconds}) \quad (\text{EQ. 4})$$

A 1nF capacitor results in a 0.2ms oscillation period. The accuracy of the period is mainly dependent on the accuracy of the capacitance and the internal current source.

Total Charge Time

The total charge time for the CC mode and CV mode is limited to a length of TIMEOUT. A 22-stage binary counter increments each oscillation period of the internal oscillator to set the TIMEOUT. The TIMEOUT can be calculated as Equation 5:

$$\text{TIMEOUT} = 2^{22} \cdot t_{OSC} = 14 \cdot \frac{C_{TIME}}{1\text{nF}} \quad (\text{minutes}) \quad (\text{EQ. 5})$$

A 1nF capacitor leads to 14 minutes of TIMEOUT. For example, a 15nF capacitor sets the TIMEOUT to be 3.5 hours. The charger has to reach the end-of-charge condition before the TIMEOUT, otherwise, a TIMEOUT fault is issued. The TIMEOUT fault latches up the charger. There are two ways to release such a latch-up: either to recycle the input power, or toggle the \overline{EN} pin to disable the charger and then re-enable it.

The trickle mode charge has a time limit of 1/8 TIMEOUT. If the battery voltage does not reach V_{MIN} within this limit, a TIMEOUT fault is issued and the charger latches up. Thus, the charger can stay in trickle mode for no more than 1/8 of TIMEOUT interval.

Monitoring Output Current thru ISET Pin

In addition to programming the fast charge current, the ISET can be used to monitor the actual output current for the AC adapter input current setting. During the constant current phase, the ISET pin voltage is fixed at 2.4V. In this case, the output current can be calculated by using 2.4V divided by R_{ISET} . During the constant voltage phase, the output current can be calculated by using the pin voltage, divided by R_{ISET} . For USB input current setting, VISET can still be used to monitor the charge current but since VISET is not used for the close loop current regulation, to achieve a good accuracy, an one-point calibration is required.

End-of-Charge (EOC) Current

The end-of-charge current I_{MIN} sets the level at which the charger starts to indicate the charge complete condition with the indication pins. The charger actually does not terminate charging until the end of the TIMEOUT interval, as described in the "Total Charge Time" on page 8. The I_{MIN} is fixed at 50mA for all input types, i.e. for AC adapter, USB high power and USB low power.

Charge Current Thermal Foldback

Overheating is always a major concern in a linear charger. The maximum power dissipation usually occurs at the beginning of a charge cycle when the battery voltage is at its minimum but the charge current is at its maximum. The charge current thermal foldback function in the ISL9219R5360 eliminates the overheating problem.

The thermal foldback function has no impact on the charge current until the internal temperature reaches approximately +125°C; then charge current is reduced at a rate of 100mA/°C. For a charger with the constant charge current set at 1A, the charge current is reduced to zero when the internal temperature rises to +135°C.

OVP Protection

The ISL9219R5360 is capable for up to 28V at the input pin. However, reliability reason, the charger will stop charging should the input voltage exceed 6V. This feature prevents excessive heating generated by the high input voltages. If an OVP condition is encountered, the PG pin will turn to high impedance to indicate the OVP condition, the charger enters the suspend state. If V_{IN} is within the power good range, the PG pin is connected to V_{IN} pin internally to provide up to 60mA supply current to the down stream circuit.

NTC Thermistor

The ISL9219R5360 provides a TS pin to monitor the battery temperature to ensure a safe charging temperature range. The temperature range is programmable with an external negative temperature coefficient (NTC) thermistor. The TEMP pin is also used to detect the removal of the battery.

The ISL9219R5360 uses two comparators (CP2 and CP3) to form a window comparator, as shown in Figure 2. When the TS pin voltage is "out of the window," determined by the V_{TMIN} and V_{TMAX} , the ISL9219R5360 stops charging and indicate a fault condition. When the temperature returns to the set range, the charger restarts a charge cycle. The two MOSFETs, Q1 and Q2, produce hysteresis for both upper and lower thresholds. The temperature window is shown in Figure 1 for a 0°C to +50°C typical application using a Mitsubishi type TH11-4H104F thermistor.

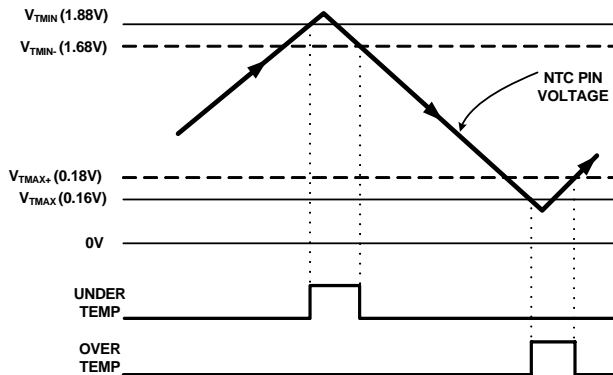

FIGURE 1. THRESHOLD VOLTAGES FOR 0°C to +50°C WINDOW

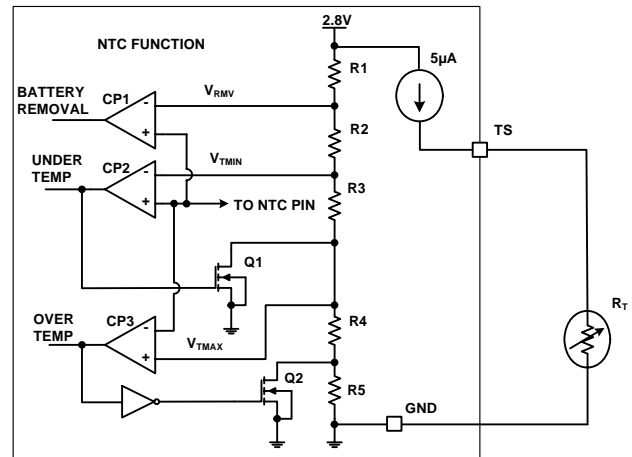

FIGURE 2. INTERNAL CIRCUIT FOR NTC INTERFACE

Battery Removal Detection

The ISL9219R5360 assumes that the thermistor is co-packed with the battery and is removed together with the battery. When the charger senses a TS pin voltage that is 2.25V or higher, it assumes that the battery is removed. The battery removal detection circuit is also shown in Figure 2. When a battery is removed, the ISL9219R5360 will enter the suspend state and the charging is halted. When a battery is inserted again, a new charge cycle starts.

Shutdown and Suspend State

The ISL9219R5360 can be orderly shutdown by one of these conditions:

1. \overline{EN} pin is pulled to logic HI
2. The battery has been removed from the charger. The battery removal condition can be detected by the TS pin (see "Battery Removal Detection" on page 9)

When shut down, the charger stays in the suspend state and draws typically less than 300µA current from the input power.

Under an OVP condition, the charger also enters the suspended state.

Input and Output Capacitor Selection

A 0.47µF or higher value ceramic capacitor for the input is recommended. Due to the inductance of the power leads of the wall adapter or USB source, the input capacitor type must be properly selected to prevent high voltage transient during a hot-plug event. A tantalum capacitor is a good choice for its high ESR, providing damping to the voltage transient. Multi-layer ceramic capacitors, however, have a very low ESR and hence when chosen as input capacitors, a 1Ω series resistor is recommended, as shown in the "Typical Application" schematic on page 5, to provide adequate damping.

When the battery is attached to the charger, the output capacitor can be any ceramic type with the value higher than

0.1 μ F. However, if there is a chance the charger will be used as an LDO linear regulator, a 10 μ F tantalum capacitor is recommended.

Board Layout Recommendations

The ISL9219R5360 internal thermal foldback function limits the charge current when the internal temperature reaches approximately +125°C. In order to maximize the current capability, it is very important that the exposed pad under the package is properly soldered to the board and is connected to other layers through thermal vias. More thermal vias and more copper attached to the exposed pad usually result in better thermal performance. On the other hand, the number of vias is limited by the size of the pad. The exposed pad is big enough for 5 vias.

State Diagram

The state diagram is shown in Figure 3. There are a total of 5 states during a complete charging cycle: trickle charge, CC charge, CV charge, charge complete/recharge, fault and suspend. In the trickle mode, the ISL9219R5360 charges the battery in a trickle current. If VOUT reaches VMIN before the

trickle charge timeout interval, the operation will move to the CC mode. Before entering the CC mode, the input source is identified. The CC mode output current is set according to the input type as described in "USB Compliant Current Setting" on page 7. When the output voltage reaches the 4.2V final voltage, the operation will move to CV mode, where the battery is charged at a constant voltage. If the end-of-charge current is reached before the timeout interval is elapsed, the operation moves to charge complete state. The charger continues to charge the battery until a timeout condition is reached, then the charging will be terminated. After the termination, if the output voltage drops below the recharge threshold, a recharge starts and the timer is reset to zero. The STAT1 and STAT2 indications remain the same as the charge complete state.

In the event that the timeout condition is reached before EOC, the fault mode is entered. The fault mode can also be triggered by an OTP event. To exit the fault mode, the input power has to be removed and re-applied, or the EN pin is toggled to HI and back to LO, then a new cycle begins.

All Intersil U.S. products are manufactured, assembled and tested utilizing ISO9000 quality systems. Intersil Corporation's quality certifications can be viewed at www.intersil.com/design/quality

Intersil products are sold by description only. Intersil Corporation reserves the right to make changes in circuit design, software and/or specifications at any time without notice. Accordingly, the reader is cautioned to verify that data sheets are current before placing orders. Information furnished by Intersil is believed to be accurate and reliable. However, no responsibility is assumed by Intersil or its subsidiaries for its use; nor for any infringements of patents or other rights of third parties which may result from its use. No license is granted by implication or otherwise under any patent or patent rights of Intersil or its subsidiaries.

For information regarding Intersil Corporation and its products, see www.intersil.com

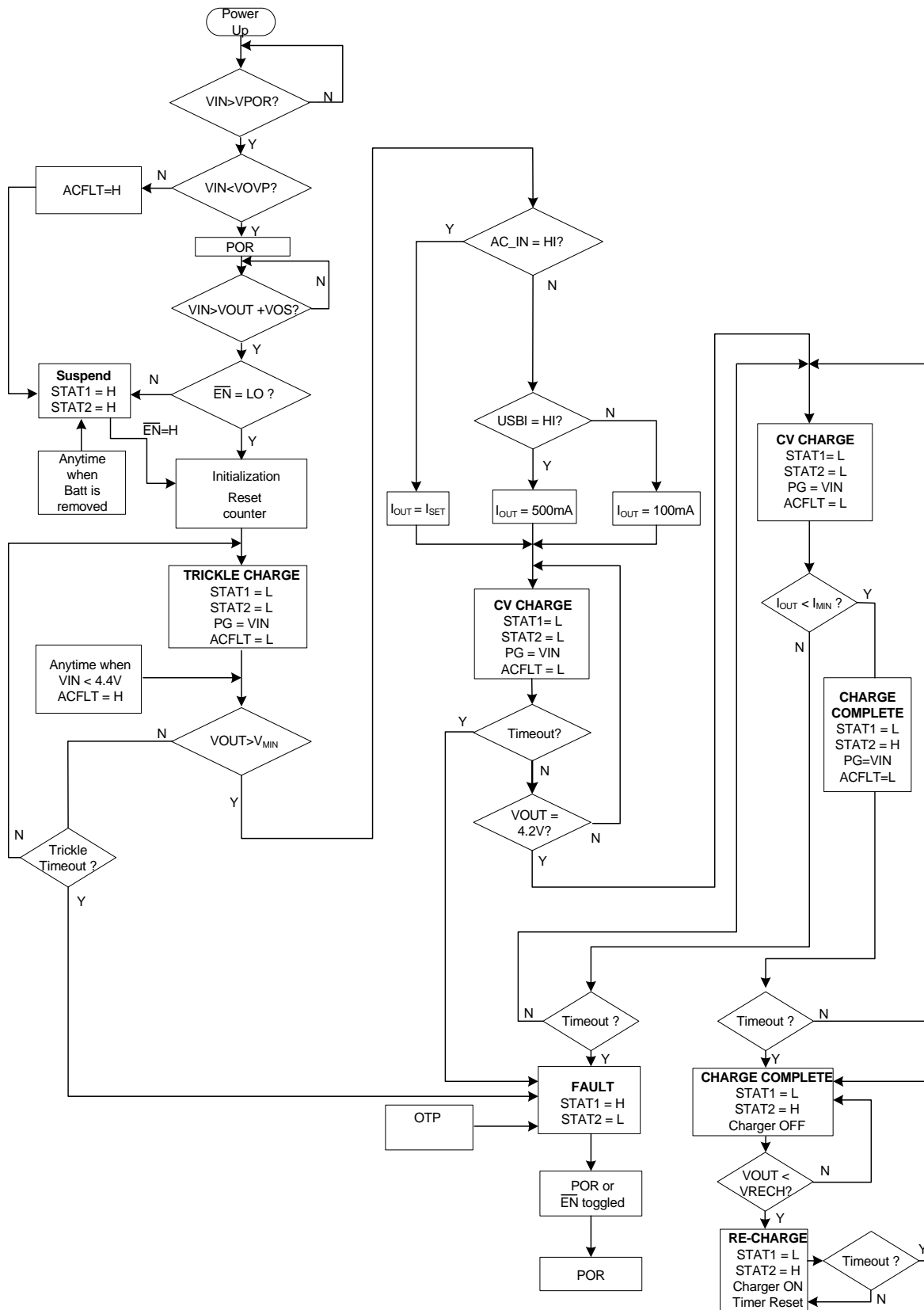

FIGURE 3. STATE DIAGRAM

Package Outline Drawing

L20.3x4

20 LEAD QUAD FLAT NO-LEAD PLASTIC PACKAGE

Rev 0, 6/07

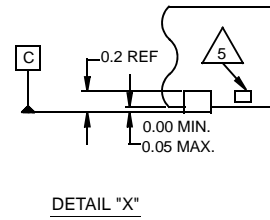
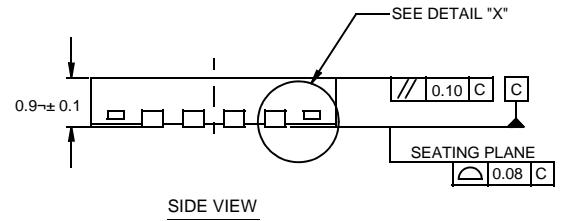
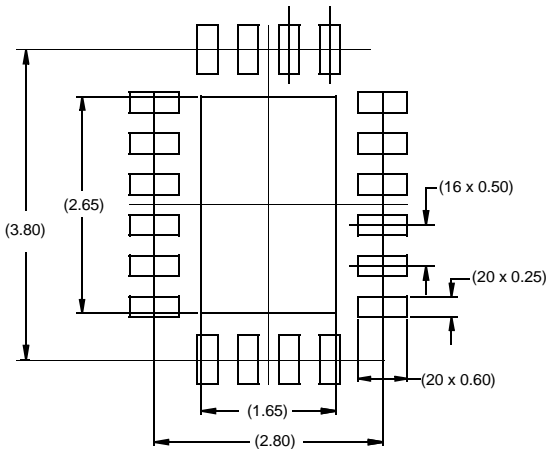
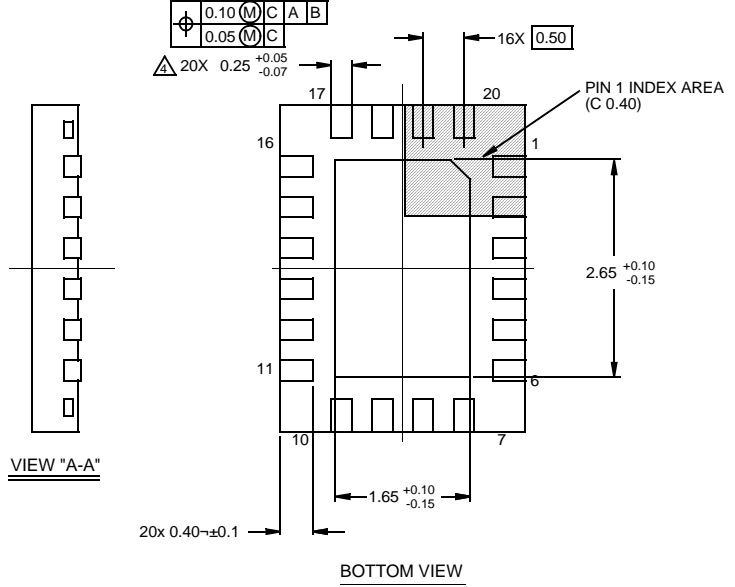
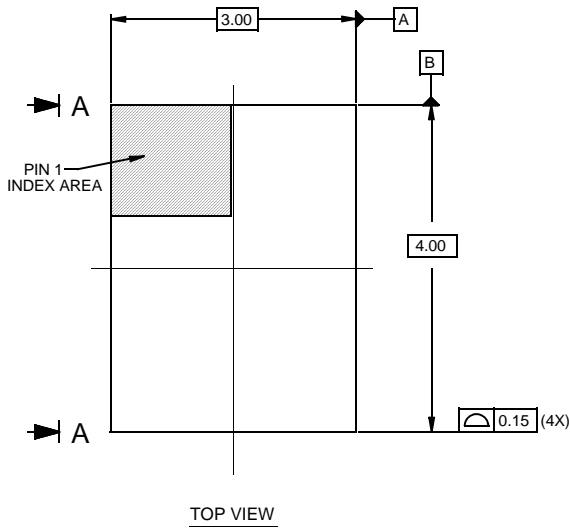

NOTES:

1. Dimensions are in millimeters.
Dimensions in () for Reference Only.
2. Dimensioning and tolerancing conform to AMSE Y14.5m-1994.
3. Unless otherwise specified, tolerance : Decimal ± 0.0
4. Dimension b applies to the metallized terminal and is measured between 0.15mm and 0.30mm from the terminal tip.
5. Tiebar shown (if present) is a non-functional feature.
6. The configuration of the pin #1 identifier is optional, but must be located within the zone indicated. The pin #1 identifier may be either a mold or mark feature.